

MOTOR MOUNTS

FORD COVER AND MOUNT



CAST ALUMINUM

Ford 352-390-406-427 & 428 cu. in.

Engineered for maximum strength. Features heat treated extruded aluminum alloy. All bolts and aluminum angle for installation are included. Adjustable stringer spacing from 22" to 28".

	Catalog No.	Item No.
Cover with Pump Drive	35202	891

FORD FLYWHEEL COVER



CAST ALUMINUM

Ford 352-390-406-427 & 428 cu. in.

Made to receive starters 1964 or later

One piece rear mounts bolt directly to the engine and are machined to receive the starter. Adjustable stringer spacing from 22" to 28".

Catalog No	Item No.
35302	908

CHRYSLER COVER AND MOUNT



CAST ALUMINUM

361-363-383-413-426 & 440 cu. in.

Designed for simple installation. Furnished with extruded aluminum angle to bolt through stringers. Adjustable stringer spacing from 22" to 28".

	Catalog No.	Item No.
Cover with pump drive for single bolt cam	35203	892
Cover with pump drive for three bolt cam	35233	901

CHRYSLER FLYWHEEL COVER



CAST ALUMINUM

361-383-413-426 & 440 cu. in.

B engines 1959 and later

Motor mounts are furnished with extruded aluminum angle to bolt through stringers. Adjustable stringer spacing from 22" to 28".

	Catalog No.	Item No.
With gear reduction starter	35303	909

NOTE: ALL MOUNTS ARE FOR A FOUR POINT APPLICATION.

MOTOR MOUNTS

PONTIAC COVER AND MOUNT



CAST ALUMINUM
Pontiac 1965-1979

Lightweight design, made from durable 356 T-6 aluminum alloy. Easy installation. All bolts, aluminum angle and pump drive are included. Adjustable stringer spacing from 22" to 28".

Catalog No.	Item No.
35204	893

BUICK COVER AND MOUNT



CAST ALUMINUM
Buick 1953-1965

Engineered for maximum strength. With heat treated extruded aluminum alloy. All bolts and aluminum angle for installation are included. Adjustable stringer spacing from 22" to 28".

	Catalog No.	Item No.
Cover with Pump Drive	35200	890

CHEVROLET COVER AND MOUNT



CAST ALUMINUM
Chevrolet 396 - 427 & 454 cu. in.

Designed to handle the horsepower and torque loads of the big block Chevrolet engine. All bolts, aluminum angle and pump drive are included. Adjustable stringer spacing from 22" to 28".

Catalog No.	Item No.
35205	894

CHEVROLET FLYWHEEL COVER



CAST ALUMINUM
Chevrolet V-6 - 327 - 350 - & 400 cu. in. (1964-2002); 396 - 427 - 454 & 502 cu. in. One piece flywheel covers bolt directly to the engine. Machined to receive starter. Easy installation. All bolts and aluminum angle are included. Adjustable stringer spacing from 22" to 28".

Catalog No.	Item No.
35305	911

NOTE: ALL MOUNTS ARE FOR A FOUR POINT APPLICATION.

MOTOR MOUNTS

CHEVROLET FRONT MOUNT



CAST ALUMINUM

Chevrolet 396 - 427 & 454 cu. in.

The most advanced design in engine mounts. Features full adjustment. Engine mounts on rubber shock pads. Reduces vibration and noise. Adjustable stringer spacing from 22" to 26".

Catalog No.	Item No.
35206	895

OLDSMOBILE FRONT MOUNT



CAST ALUMINUM

Oldsmobile 425 & 455 cu. in.

Adjustable rubber front mount reduces vibration, and lowers noise levels. Adjustable stringer spacing from 22" to 26".

Catalog No.	Item No.
35207	896

CHEVROLET FLYWHEEL COVER



CAST ALUMINUM

Chevrolet 396 - 427 & 454 cu. in.

A companion mount to Glenwood's #895 rubber front motor mount. These mounts are fully adjustable and install easily in a variety of deep vee hulls. Adjustable stringer spacing from 22" to 26".

Catalog No.	Item No.
35306	912

OLDSMOBILE FLYWHEEL COVER



CAST ALUMINUM

Oldsmobile 425 & 455 cu. in.

One piece flywheel cover with fully adjustable rubber mounts. These mounts are easily installed. Adjustable stringer spacing from 22" to 26".

Catalog No.	Item No.
35307	913

NOTE: ALL MOUNTS ARE FOR A FOUR POINT APPLICATION.

MOTOR MOUNTS

CHEVROLET FRONT MOUNT



CAST ALUMINUM

Chevrolet V-6-283-327 & 350 cu. in.
Chevrolet 396-427-454 & 502 cu. in.

These mounts will adapt to engine stringer spacing from 22" to 26".

	Catalog No.	Item No.
Small Block	35209	1292
Big Block	35210	897

CHEVROLET REAR MOUNT

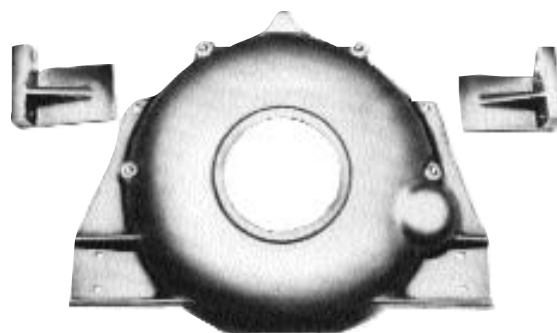

CAST ALUMINUM

Chevrolet V-6-283-327 & 350 cu. in.
Chevrolet 396-427-454 & 502 cu. in.
(1964-2002)

Bolts directly to engine, machined to receive starter. Engine stringer spacing from 22" to 26".

Catalog No.	Item No.
35310	914

OLDSMOBILE FRONT MOUNT



CAST ALUMINUM

Oldsmobile 425 & 455 cu. in.

Highly polished aluminum finish.
Durable lightweight construction. Engine stringer spacing from 22" to 26".

Catalog No.	Item No.
35211	898

OLDSMOBILE REAR MOUNT

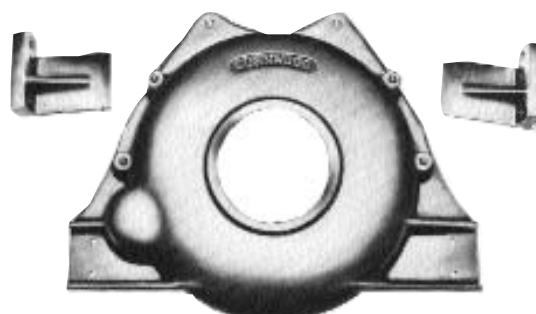

CAST ALUMINUM

Oldsmobile 425 & 455 cu. in.

Bolts directly to engine. Machined to receive starter. Engine stringer spacing from 22" to 26".

Catalog No.	Item No.
35311	915

NOTE: ALL MOUNTS ARE FOR A FOUR POINT APPLICATION.

MOTOR MOUNTS

FORD FRONT MOUNT

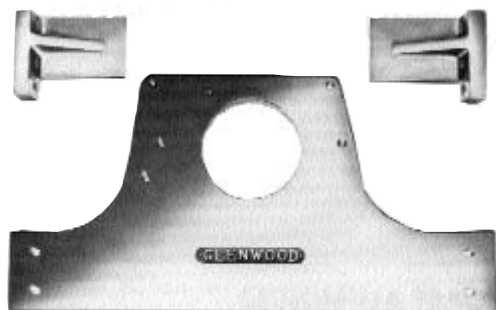

CAST ALUMINUM
Ford 429-460 cu. in.

Perfect mount for big block Ford V-8. Engine will adapt to stringer spacing from 22" to 26".

Catalog No.	Item No.
35214	900

FORD REAR MOUNT

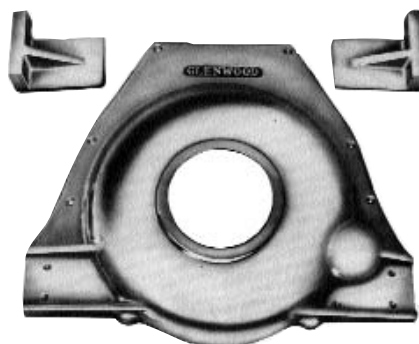

CAST ALUMINUM
Ford 429-460 cu. in.

Highly polished aluminum finish. Bolts directly to engine. Precision machined to receive starter motor. Stringer spacing from 22" to 26".

Catalog No.	Item No.
35314	917

BORG WARNER/CHEVROLET REAR MOUNT WITH TOP MOUNT STARTER



Designed for boats equipped with Borg Warner Velvet drive transmissions. Features 'top-mount' starter placement for easy access and corrosion protection. Uses Delco Starter #1109485.

Catalog No.	Item No.
32400	1640
Polished 32401	1641

BORG WARNER/CHEVROLET REAR MOUNT STANDARD

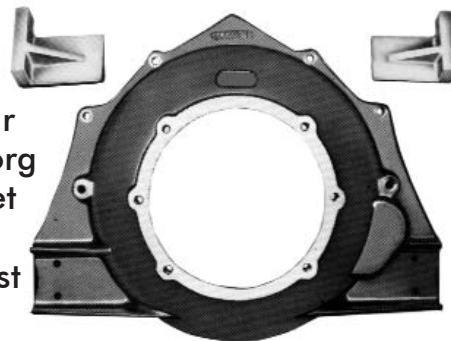

Standard rear mount for Borg Warner Velvet drive transmissions. Cast aluminum.

Catalog No.	Item No.
32424	781
Polished 32425	784

NOTE: ALL MOUNTS ARE FOR A FOUR POINT APPLICATION.

MOUNTS • DAMPERS • HOSE

BORG WARNER FORD REAR MOUNT

Ford 429 - 460

Fits Borg Warner transmissions. Use either a small or large flywheel, but must have stock plate that fits between engine and transmission.

Catalog No.	Item No.
32414	782



BORG WARNER OIL COOLER HOSES



Fits Borg Warner transmissions. Hoses are 15" and 18" and are sold in pairs.

Catalog No.	Item No.
32420	788

BORG WARNER DRIVE DAMPER

For use with Borg Warner 71 and 72 transmissions. Made to go onto the clutch flywheel.

Catalog No.	Item No.
32406	779

